

# THE LAST NUCLEAR BOMB MEMORIAL

študent:  
vedúci práce:  
garant predmetu:  
vertikálny ateliér:  
akad. rok:

Jakub Janotka  
doc. Ing. arch. Ján Legény, PhD.  
doc. Ing. arch. Alexander Schleicher, PhD.  
Legény / Morgenstein - "Out of the Box"  
2023/24



# ATÓMOVÉ MOCNOSTI



- SPOJENÉ ŠTÁTY AMERICKÉ
- SPOJENÉ KRÁLOVSTVO
- FRANCÚZSKO
- IZRAEL
- PAKISTAN
- INDIA
- RUSKO
- ČÍNA
- SEVERNÁ KOREA

# KONCEPT



# CESTA K NÁVRHU POMOCOU MIDJOURNEY



# KONCEPT

RAMPA AKO HLAVNÝ  
ARCHITEKTONICKÝ PRVOK  
OBJEKTU

VÝSLEDNÝ OBJEKT

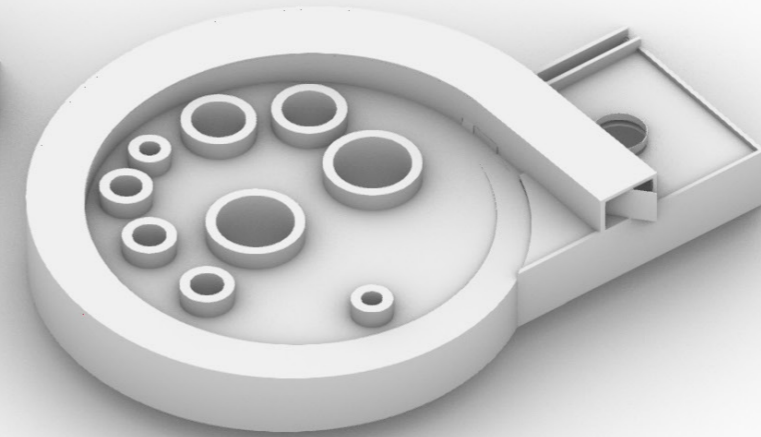
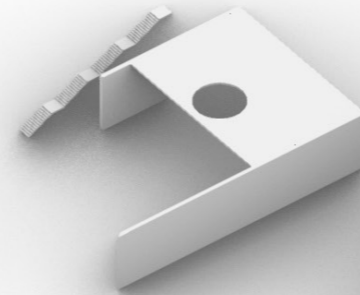
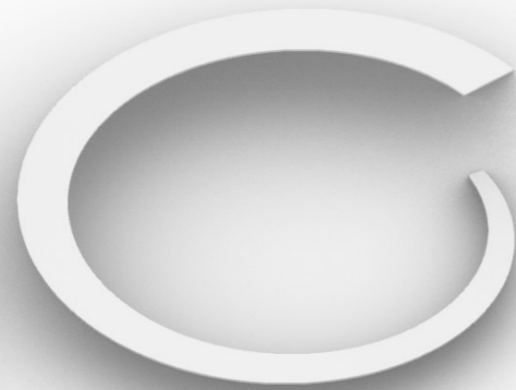
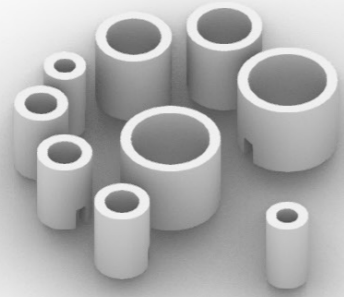

JEDNOTLIVÉ OBJEKTY  
ZNÁZORŇUJÚ KRAJINY S  
JADROVÝM ARZENÁLOM

SEKUNDÁRNY OBJEKT  
SO ZÁZEMÍM

# SITUÁCIA

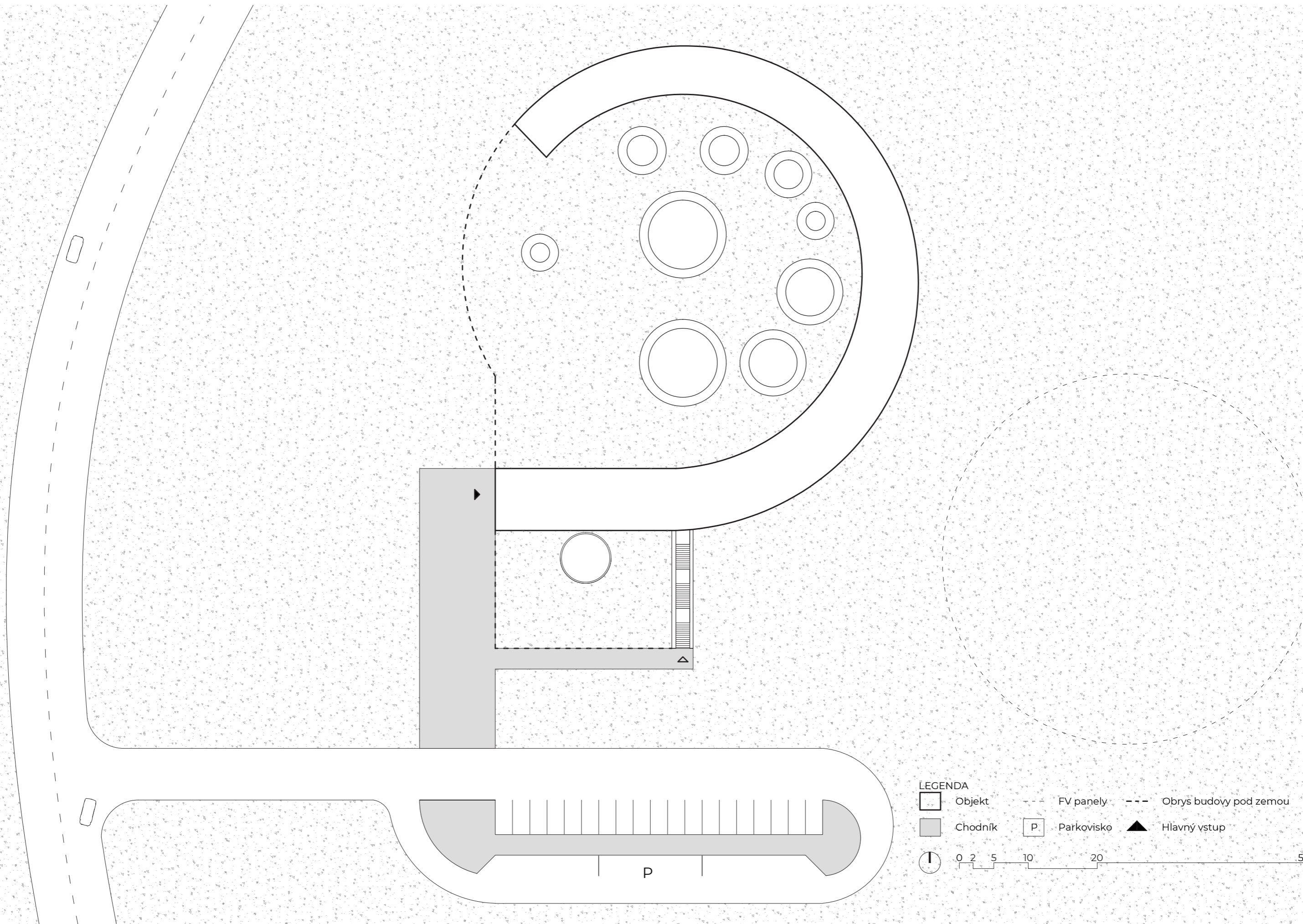

## LEGENDA

- Objekt
- Chodník
- FV panely
- Parkovisko
- Obrys budovy pod zemou
- Hlavný vstup



# PREVÁDZKOVÝ KONCEPT

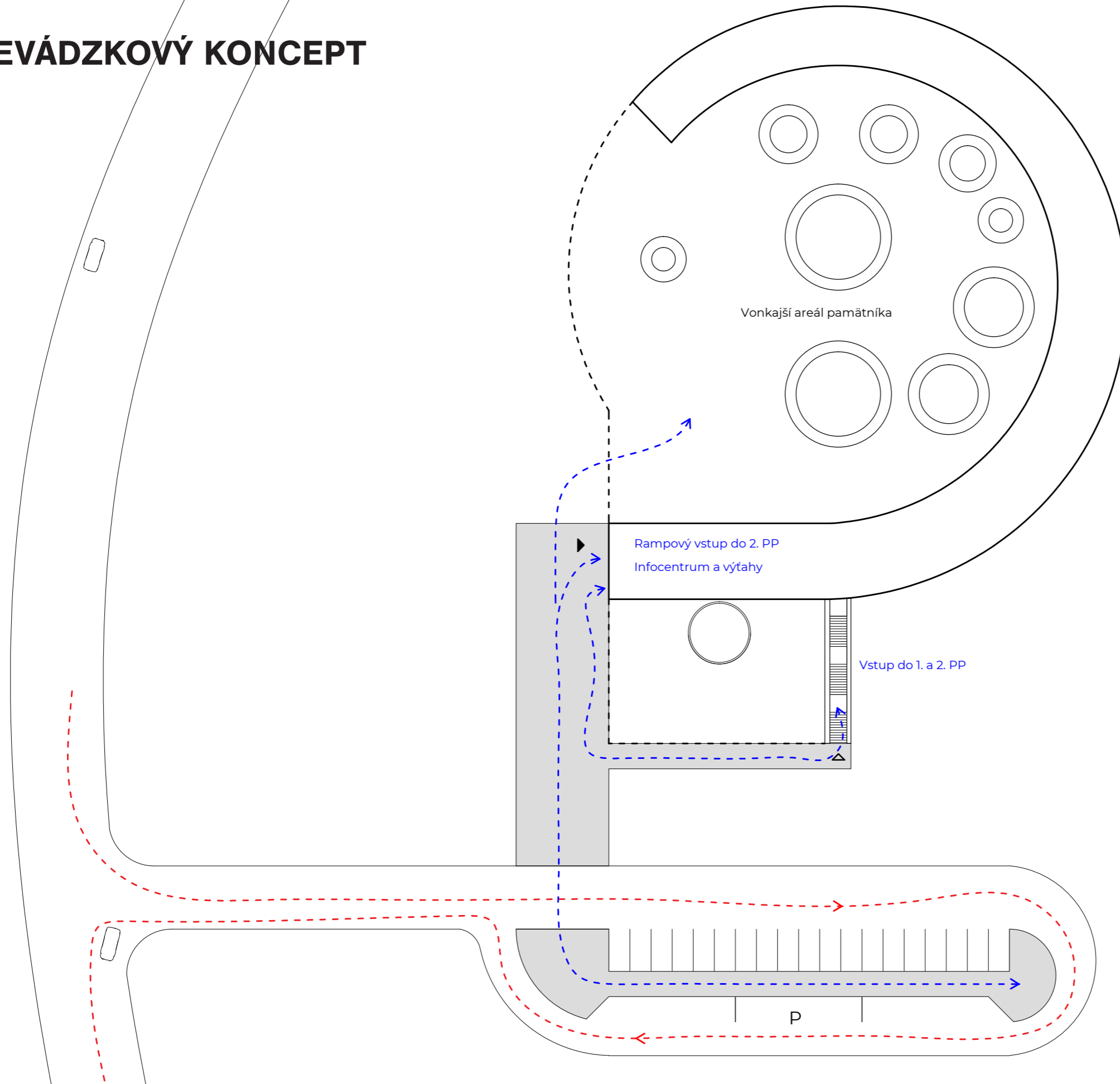

## LEGENDA

- Objekt
- Chodník
- Parkovisko
- Obrys budovy pod zemou
- Trasovanie vozidiel
- Trasovanie chodcov
- Hlavný vstup

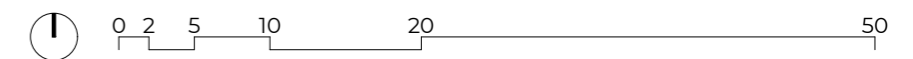

# PŌDORYS 1. NP

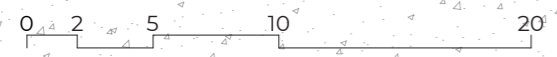
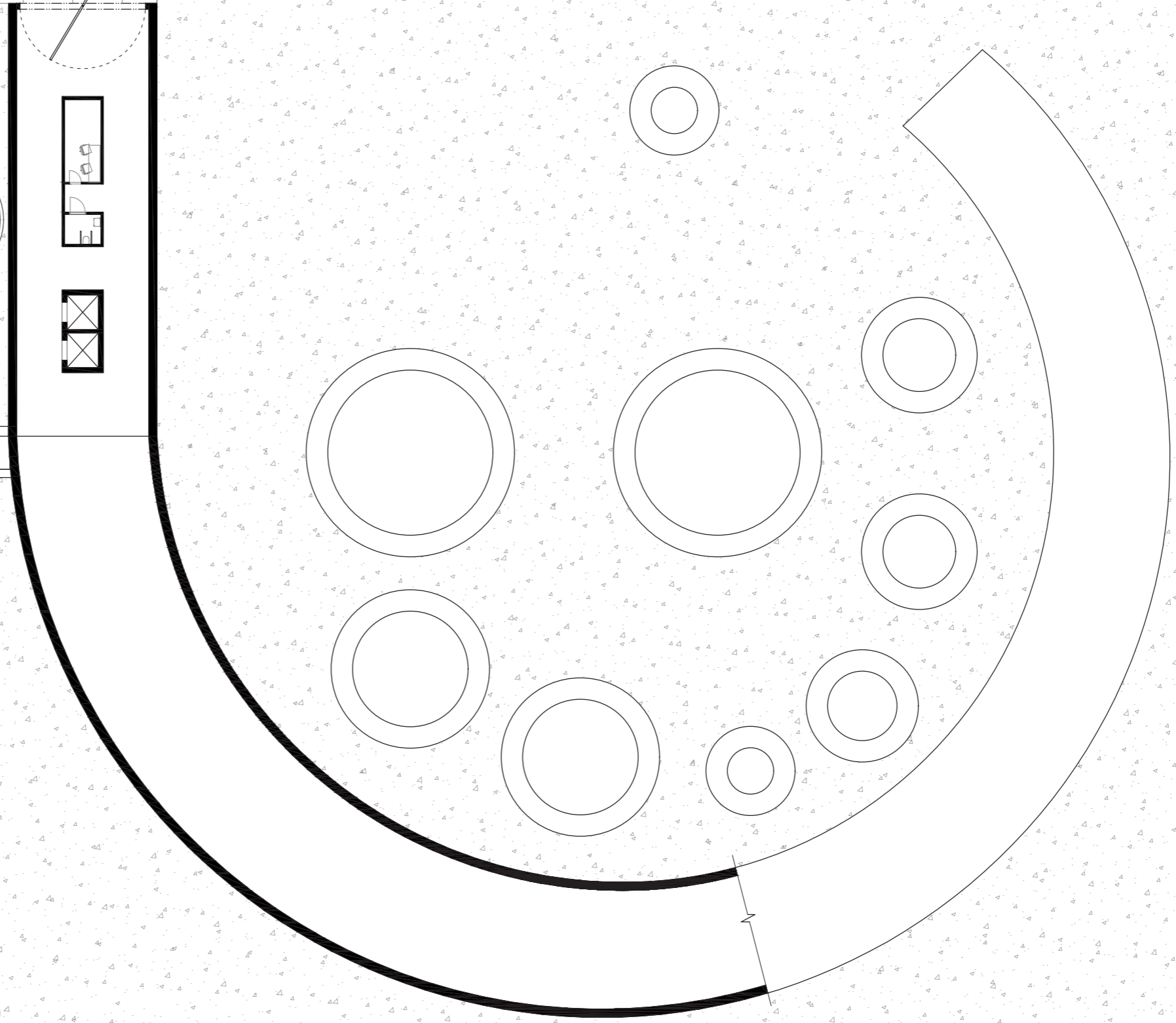
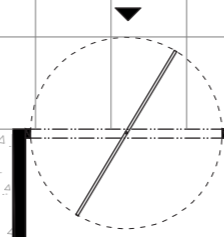
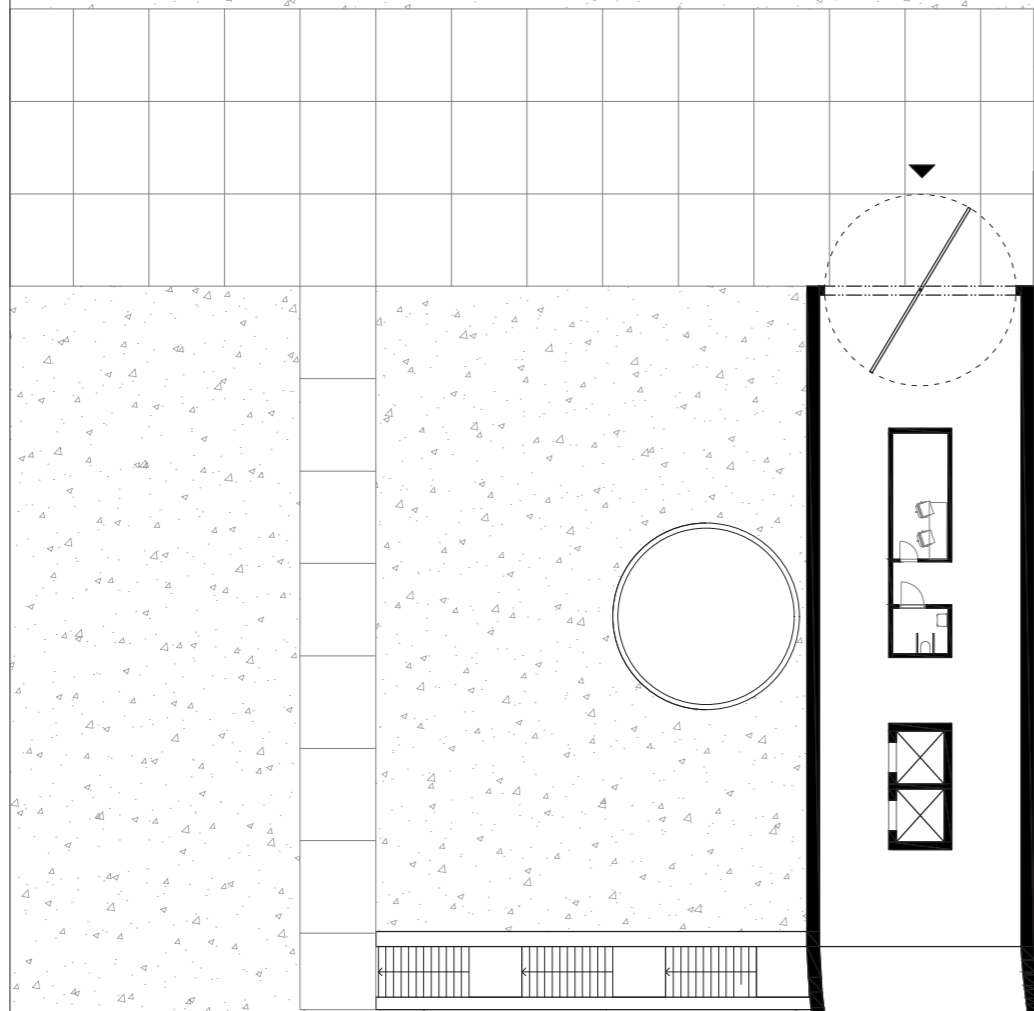



# PŌDORYS 1. NP

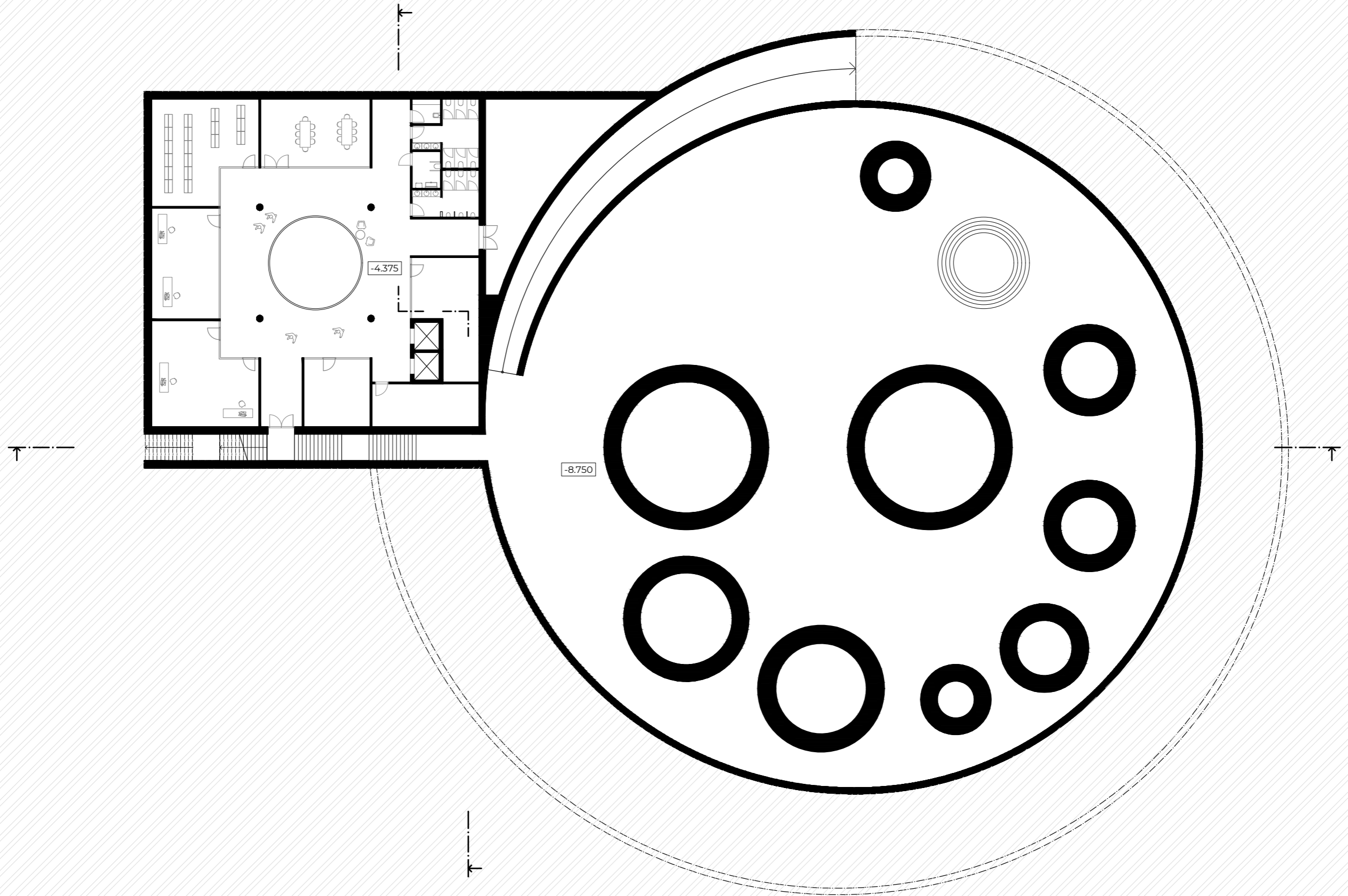

# PŌDORYS 1. PP

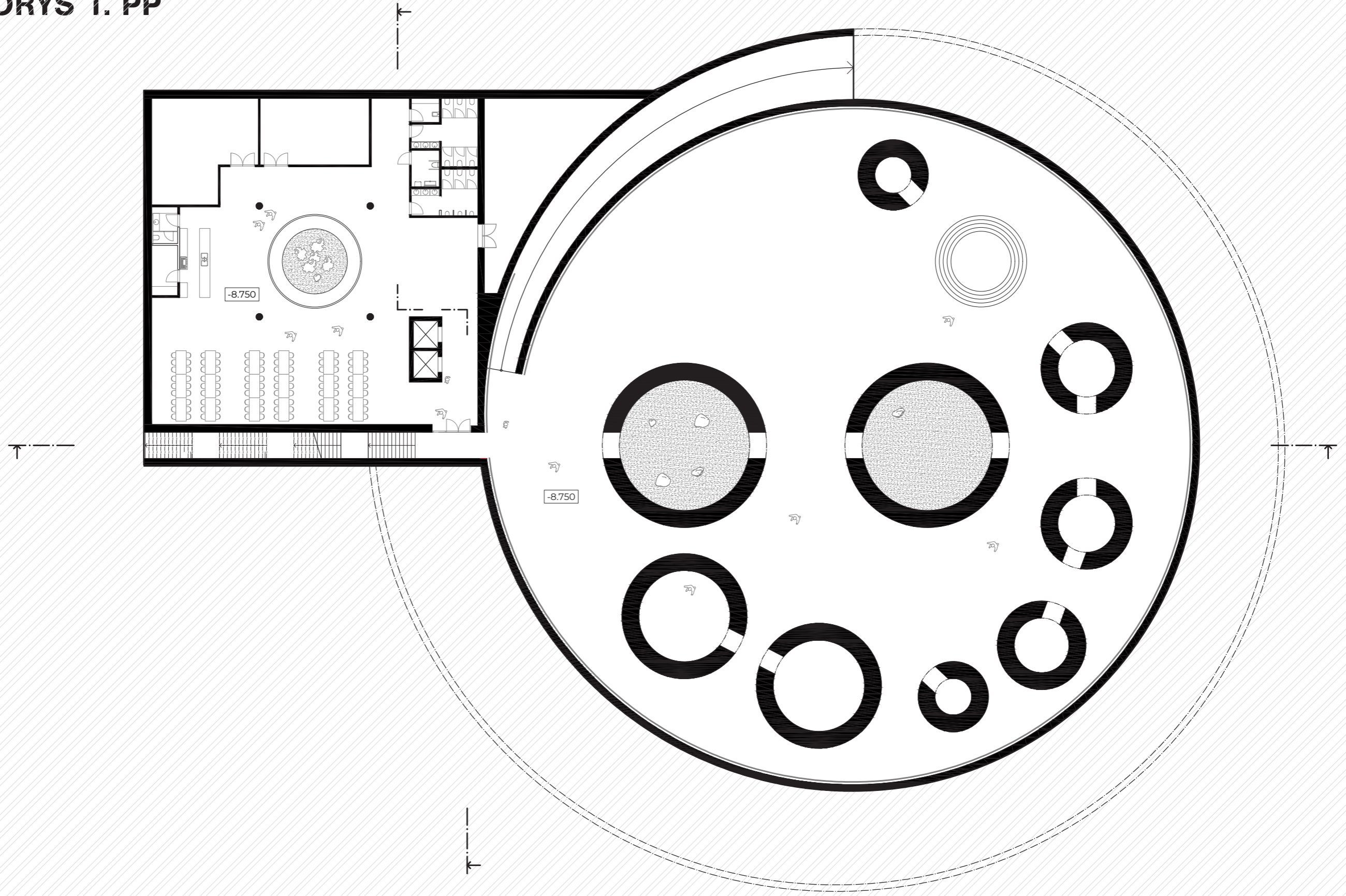

# PÔDORYS 2. PP

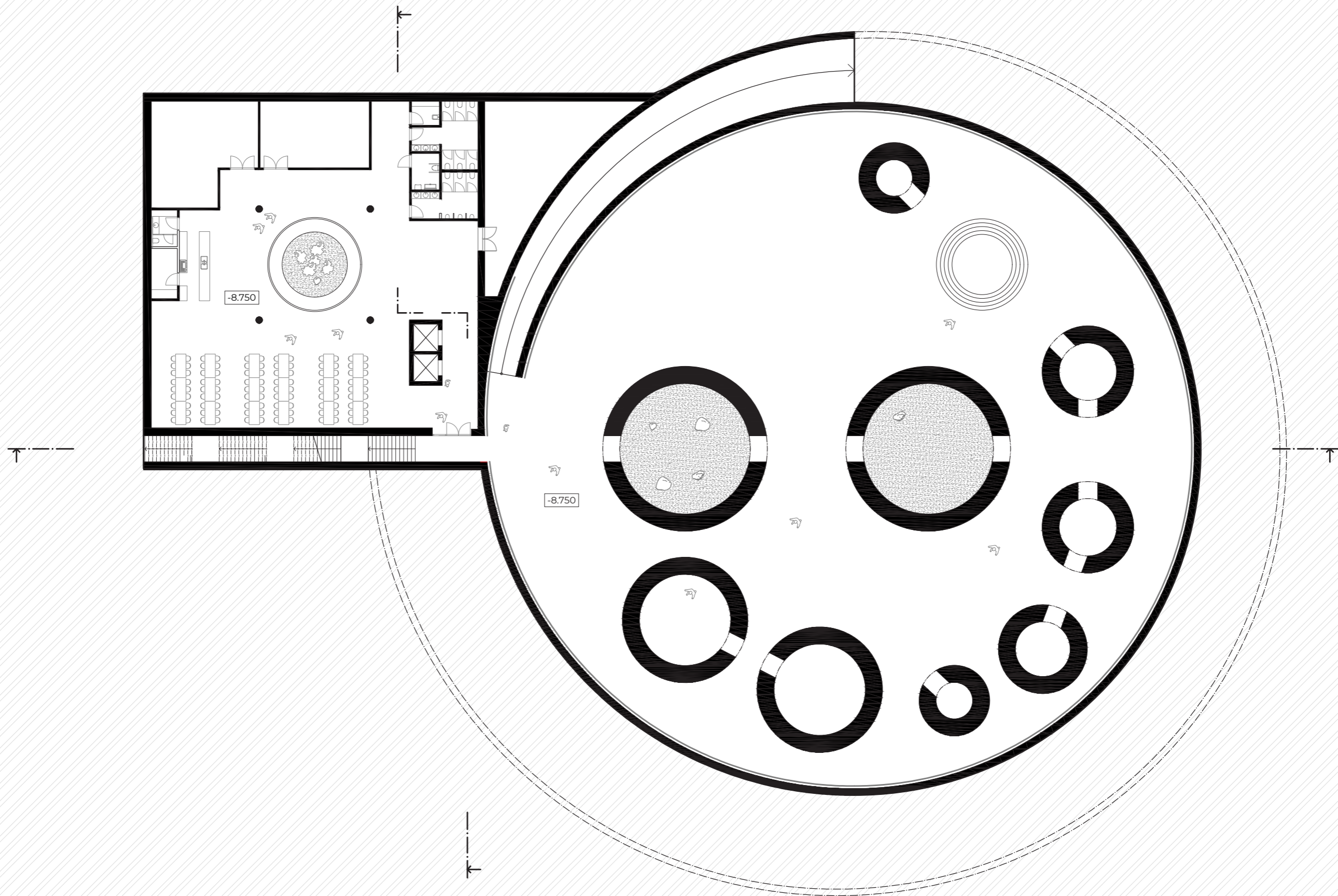

# REZ A-A'

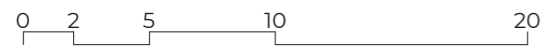
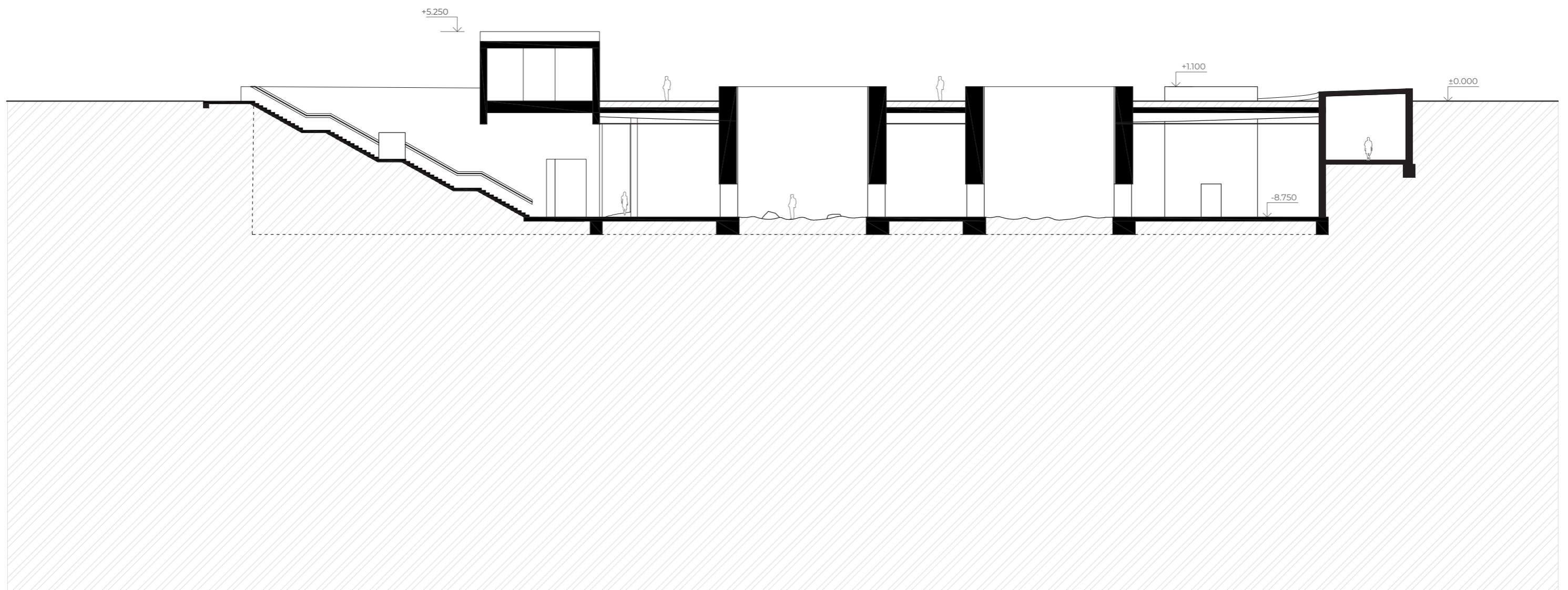

# REZ B-B'

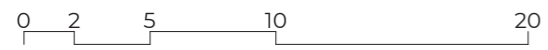
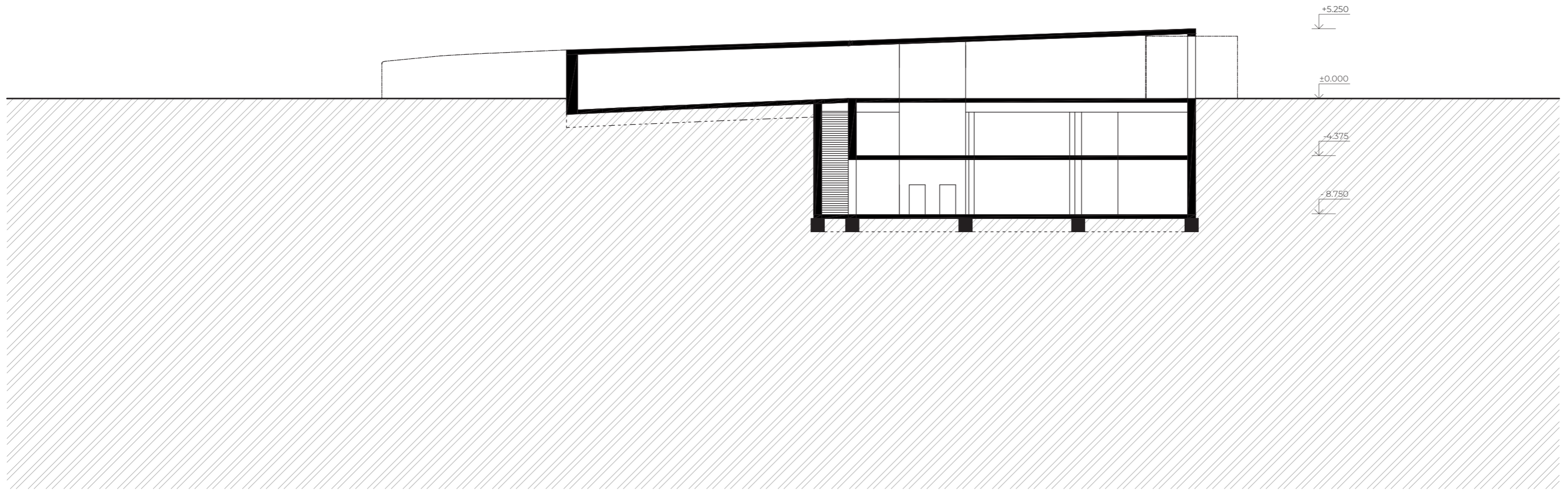

# AXONOMETRIA



# HLAVNÝ VSTUP

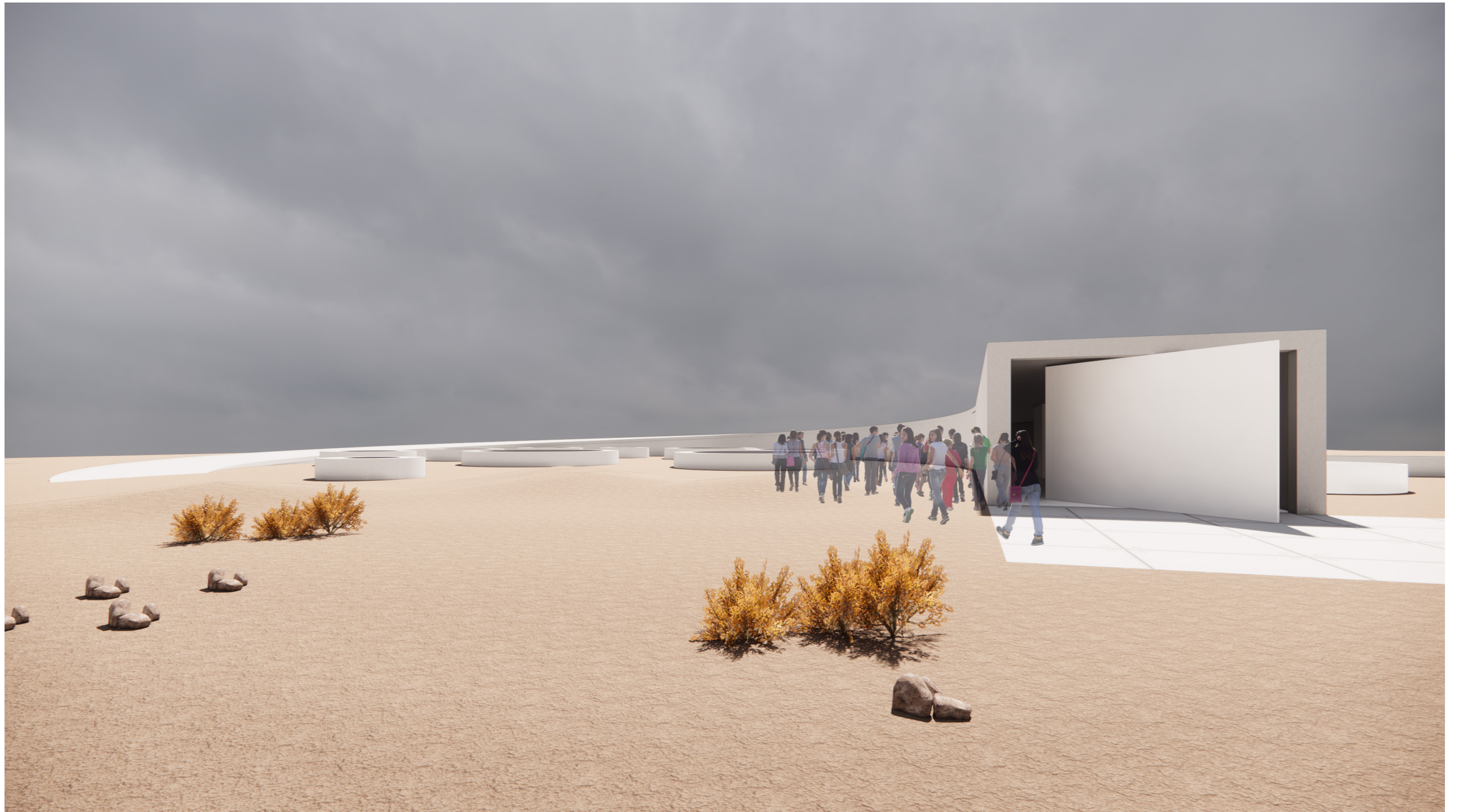

# VEDĽAJŠÍ VSTUP

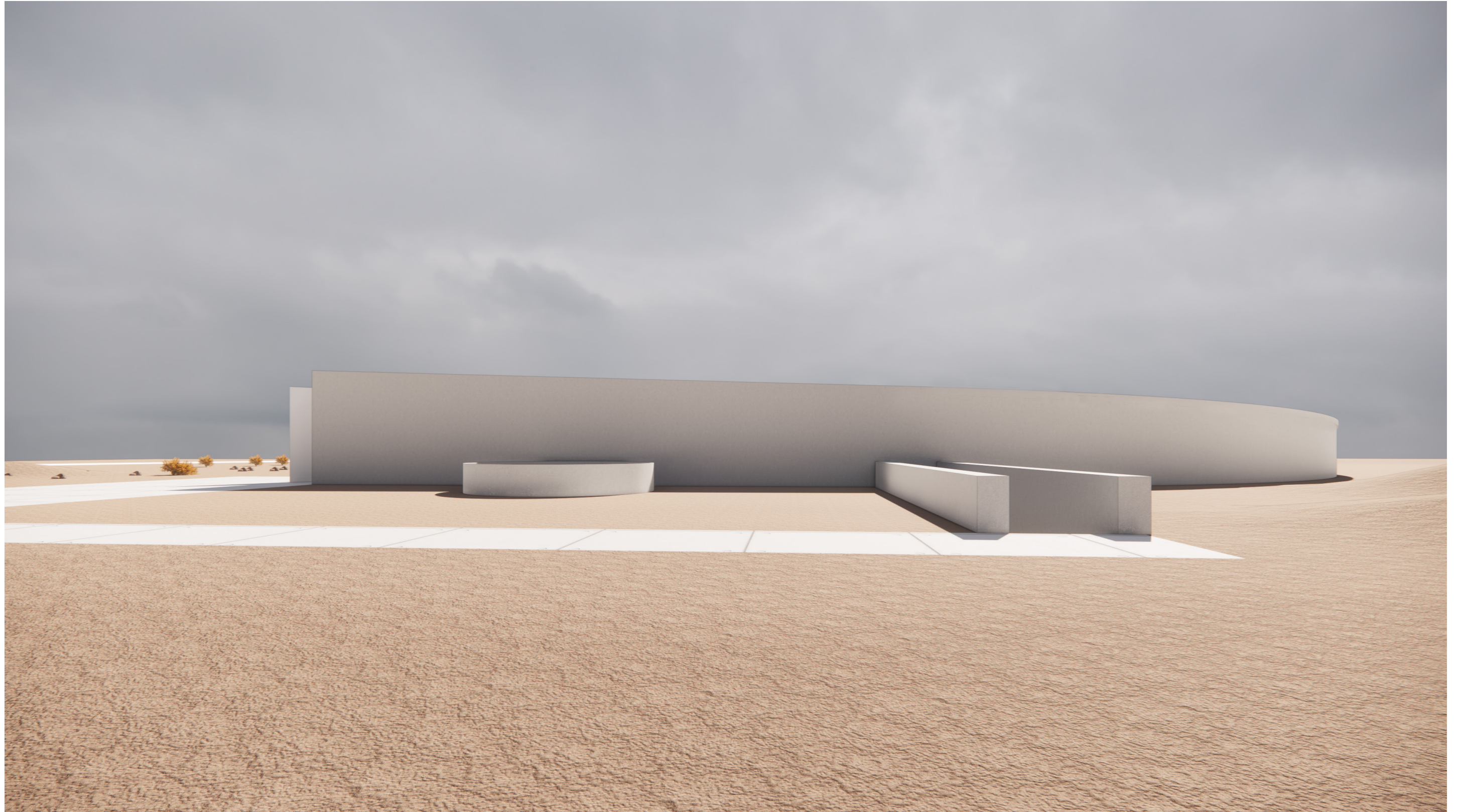



# SCHODISKO



## PRÍKLAD UMIESTNENIA UMELECKÉHO DIELA



# KOMUNIKAČNÝ UZOL



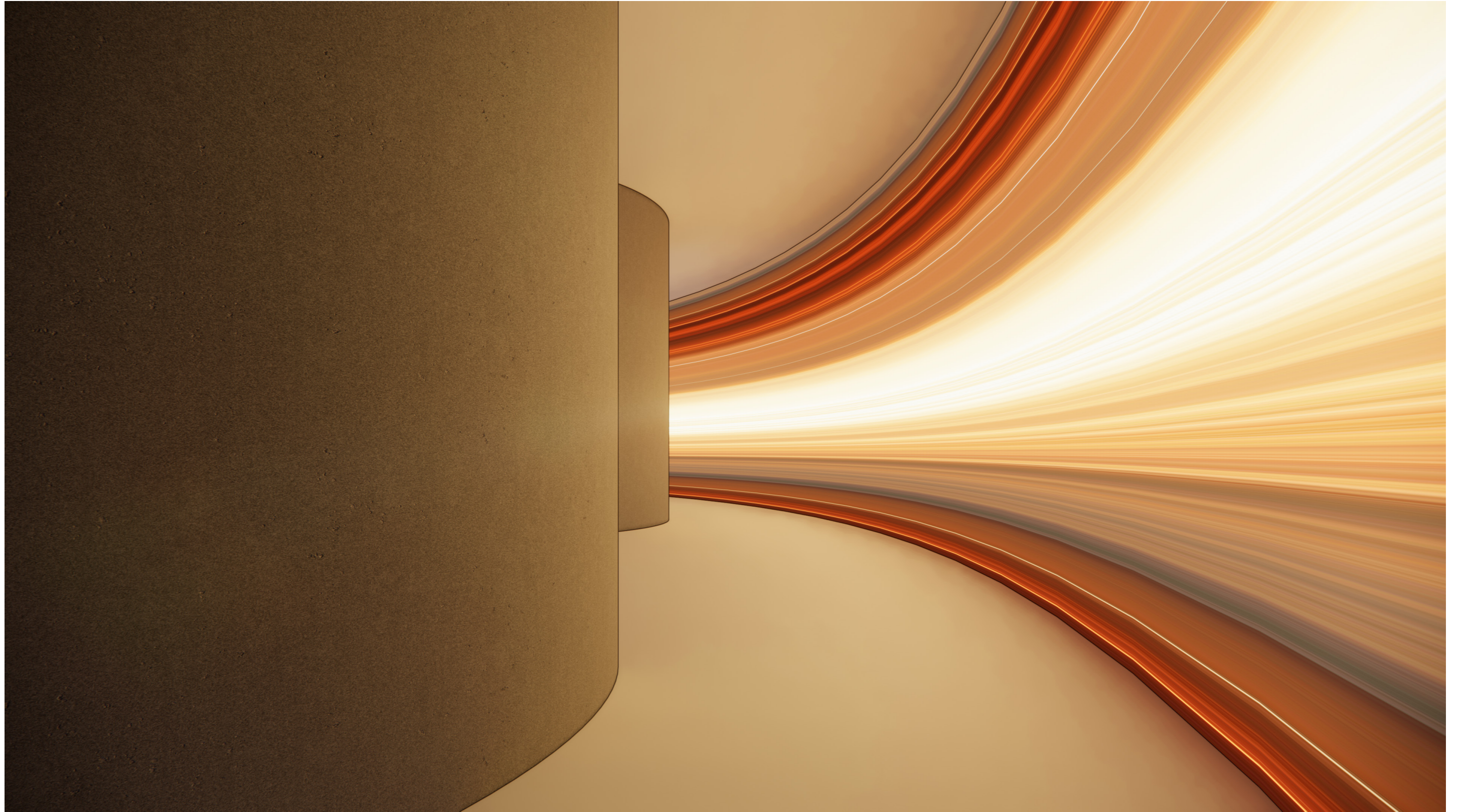

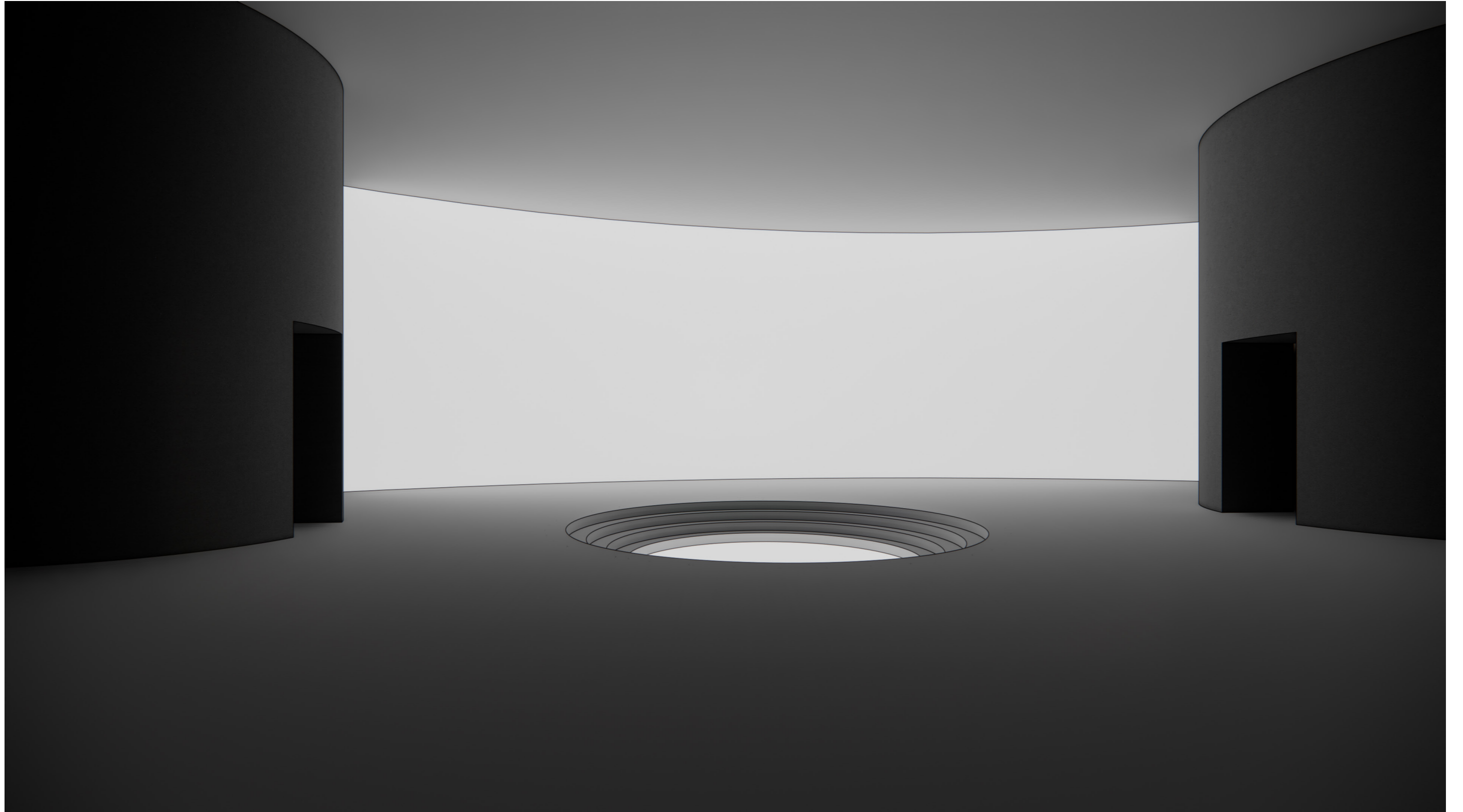



**ĎAKUJEM ZA POZORNOST**